

Composite Gas Measurement System using NDIR Method

Ik-soo Eo

Department of Electrical Engineering, Honam University

NDIR 방법을 이용한 복합 가스 측정 시스템

어익수

호남대학교 전기공학과

Abstract The current study was conducted to develop a portable composite gas detector allowing the detection of both CO₂ and CH₄ gases by means of the Non Dispersive Infra-Red (NDIR) method. The gas detector is configured to radiate infrared waves using infrared lamps, where the wavelength of the infrared light is reduced due to absorption throughout the chamber, and this reduction (absorption) is detected by the absorption detector, before being converted and amplified to a 3.5V~6V electrical signal, providing as accurate a measurement as possible. The conventional single sensor method measures the relative measurement by absorbing only specified wavelengths of infrared radiation, which in the case of gas detection leads to problems with accuracy due to the lack of a reference sensor when detecting light with a wavelength of only 4.26 μ m. The dual sensor employed in this study provides a comparative measurement between the reference value derived from the wavelength of 3.91 μ m, which is not influenced by other gas sources, and the measurement value derived from the wavelength of 4.26 μ m, in order to reduce the errors and enhance the reliability, thereby allowing low power consumption for portable devices and multi-gas detection for both CO₂ and CH₄ gases. The portable composite gas detector developed herein provides a measurement range of 0ppm~5,000ppm for CO₂ gas, and 0.5%vol for CH₄, which allows the determination of whether the CO₂ and CH₄ contents in indoor air are less than 1,000ppm or not. The current study established that the composite gas detector can be interlinked with firefighting appliances through portable devices or home automation, and is anticipated to be very effective in fire prevention.

요약 본 논문은 NDIR(Non Dispersive Infra Red) 방식을 적용하여 CO₂ 및 CH₄의 두 가지 가스를 하나의 휴대용 장치에서 측정이 가능하도록 제작된 복합 가스 측정 장치에 대한 연구이다. 측정 장치의 구성은 적외선램프에서 적외선이 방출되면 방출된 파장이 광확장을 거치면서 흡수로 인하여 빛이 줄어들게 되고 이 감소량(흡수도)을 검출기에서 검출하고 이를 전기적 신호로 변환 증폭하여(3.5V~6V) 정확한 측정이 가능함을 보여준다. 기존의 Single Sensor 방식은 적외선에서 특수파장을 흡수하여 상대 측정량을 검출하는 방식으로 가스의 경우 4.26 μ m파장의 빛만을 검출하여 측정하는 방식으로 센서의 값을 보정할 수 있는 기준센서가 없어 오차가 발생하는 문제가 발생하였다. 본 연구에 적용된 Dual Sensor 방식은 다른 가스의 영향을 받지 않는 3.91 μ m의 기준치와 가스의 4.26 μ m의 두 파장을 검출하여 비교측정 함으로써 오차가 적어 신뢰도가 높은 방식으로, 휴대용으로 소형화하여 저 전력화가 가능하며, CO₂ 및 CH₄의 2가지 가스농도를 복합적으로 측정 할 수 있다는 특징이 있다. 측정 범위는 CO₂의 경우 0ppm~5,000ppm이고 CH₄의 경우는 0~5%의 부피 농도로 실내 공기량 1,000ppm을 측정 할 수 있도록 제작되어 휴대용이나 주택의 Home automation과 연동하여 소화연동이 가능하므로 화재예방에 매우 효과적인 것으로 확인하였다.

Key Words : CH₄, CO₂, Gas sensor, Home network, Infra red, NDIR.

*Corresponding Author : Ik-Soo Eo(Honam Univ.)

Tel: +82-62-940-5496 email: iseo@honam.ac.kr

Received October 27, 2017

Revised (1st January 25, 2017, 2nd February 19, 2018)

Accepted March 9, 2018

Published March 31, 2018

1. Introduction

Following the increased numbers of large multi-purpose complexes, the indoor air quality has become an important factor for people's life. The guideline provided by the Ministry of Environment for maximum gas content is 10ppm for carbon monoxide, 1,000ppm for carbon dioxide and PM10 for fine dust. Carbon dioxide has no color, smell nor taste, and along with carbon monoxide, is one of the major indoor air pollutant. Accomplishing industrialization in a relatively short period caused the air quality to rapidly deteriorate from the increased energy consumption and usage of cars, which lead to efforts providing real time feedback on the air quality to the general public[1].

Exhaust gas of automobiles includes CO₂ and H₂O. However by-products such as CO, unburned fuel, HC smoke, Pb compounds, SO₂ and NO_x are also emitted from automobiles. Especially, CO₂ is a main contributor to global warming as it absorbs infrared radiation from the earth to the atmosphere with wavelength of 4.26 μ m. High concentration of carbon dioxide causes difficulty in breathing. A human body shows faster breathing at CO₂ concentration of 30,000ppm, difficulty in breathing and headaches at 40,000ppm. The human body can briefly withstand CO₂ concentrations exceeding 50,000ppm, however a lengthy exposure to such concentration may lead to dyspnea and potentially suffer permanent damage. Recently LNG is widely supplied to residential areas through underground and overground pipes. LNG, mainly composed with methane (CH₄) also includes light paraffinic hydrocarbons such as ethane. Methane (CH₄) is non-toxic and relatively stable, however it imposes explosive and combustive hazards, and under high concentrations it may cause anoxia(suffocation). The recent development of the instant water heater market introduces higher possibilities of carbon monoxide accumulation and potentially fatal consequences due to incomplete combustion of LNG. Thus regulations obligate measures to detect and alarm

carbon monoxide concentration and leaks in advance. In case of the recently emerging home network systems, systems monitoring LNG leakage and shutting down LNG supply under hazardous circumstances are generally applied with non dispersive IR carbon dioxide gas sensors. Conventional gas sensors adapt methods measuring the conductivity of the gas through electro-chemical sensing, catalytic sensing, and contact sensing. These methods are highly sensitive to the ambient temperature and humidity which damages the integrity of their accuracy[2, 3]. Accordingly, non dispersive IR type sensing technology has emerged as alternatives and its application has widen than before. Among such technology, NDIR method is universally accepted. The NDIR method utilizes the IR absorption peak at 4.26 μ m and 3.31 μ m wavelength for CO₂ and CH₄ molecules, respectively[4, 5].

This current study focuses on NDIR method gas sensors accurately measuring the CO₂ and CH₄ concentration in indoors of multi-purpose facilities, apartments, skyscrapers, large underground shopping complexes and houses, to ensure the safety of users.

2. NDIR Measurement

2.1 Absorption Wavelength of Atmospheric Gases

The source of IR Gas Monitor is infrared lamps. The range of infrared waves radiated by the IR lamp varies between 3 μ m~25 μ m, which is categorized as Mid IR. Fig. 1, shows the absorption spectrums of several atmospheric gases including methane.

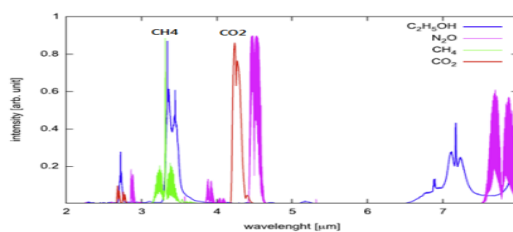

Fig. 1. IR Absorption Spectrums

In general an atmospheric liquid or gas can have three different optical phases. First, a molecule can absorb IR photons, where the photons are absorbed on a 1 : 1 reaction with molecules. Second, a molecule in an excited state can naturally emit absorbed photons to settle down to a ground state. Third, the molecule can be at equilibrium constantly absorbing and emitting photons. Table 1. shows the absorption center wavelength of several gases. The center wavelength with the largest band intensity is commonly selected, where 4.26 μm is selected for CO₂ gas, and 3.31 μm is selected for CH₄ gas. However considering the different band intensity of methane, 10.8x10⁻¹⁸(cm⁻¹ molecule⁻¹ cm⁻²) and CO₂, 95.5x10⁻¹⁸(cm⁻¹ molecule⁻¹ cm⁻²), methods to differentiate sensors should be considered, including improving the intensity of incident light.

Table 1. Absorption Center Wavelength and Band Intensity by Gas

Gas	Center Wavelength(μm)	Band Intensity (10 ⁻¹⁸ cm ⁻¹ molecule ⁻¹ cm ⁻²)
CO ₂	4.28	7.4
	4.26	95.5
	2.77	1.0
	2.69	1.6
N ₂ O	7.78	8.2
	4.53	5.7
	4.50	50.0
	3.90	1.2
CO	2.87	1.7
	4.67	9.8
CH ₄	7.63	5.0
	3.31	10.8

2.2 The Beer–Lambert Law and Non Dispersive Infrared Sensors

Molecules existing on an infrared line causes the gas molecules to absorb IR according to their concentration, which eventually reduces the intensity of infrared lights arriving at the infrared sensor. The Beer-Lambert Law, Formula 1, defines the relation between the amount of IR absorption and the gas concentration. Assuming

every parameter forming the Beer-Lambert Law formula, except the intensity arriving at the sensor (I_d) and gas concentration (X), are constant, the gas content can be calculated based on the intensity of light arriving at the sensor.

$$I_d = I_o \cdot \exp(-\alpha \cdot X \cdot L) \quad (1)$$

Where:

I_d is the intensity of light arriving at the sensor (W/cm²);

I_o is the intensity of light at its source (W/cm²);

α is the absorption coefficient of the gas;

X is the gas content (ppm); and

L is the length of the optical path.

Thus, for methods using gas contents, securing a structure embracing a higher gas content, where a longer optical path is available within the limited space is essential.

2.3 Vibration of Methane Molecules

The molecular vibrations of a methane molecule has a relatively weak absorption spectrum, making measurement of differentiated intensity through absorption difficult. Thus, the Raman spectroscopy is applied to measure the fluctuation in wavelength by scattering light.

Table 2. Vibration of Methane Molecules Characteristic

Mode	v1	v2	v3	v4
Vibration	Symmetr-ic stretch	Twisting	Asymm-etric Stretch	Bending
Measurement	Raman Spectroscopy	Raman Spectroscopy	Infrared Spectroscopy	Infrared Spectroscopy
Wave Number (σ)	2917cm ⁻¹	1533cm ⁻¹	3019cm ⁻¹	1306cm ⁻¹
Wave Length (λ)	3.43 μm	6.52 μm	3.31 μm	7.63 μm

Table 2. defines the characteristics of basic vibration modes. The wave number of each vibration modes shows a correlation of (v1) \approx (v3) \approx 2(v2) \approx 2(v4). In this current study, methane molecules with a strong band intensity at 3.31 μm are sensed with infrared spectroscopy.

3. Experiment and Results

3.1 System Configuration

As illustrated in Fig. 2, infrared light with wavelength of $4.26\mu\text{m}$ is radiates through the chamber and is absorbed by gas molecules within the chamber. The absorbed amount is measured by the IR detector, converted into digital signals. This digital signal is then amplified to provide measurement of concentration which completes the mechanism of Focus Radiation NDIR Detector.

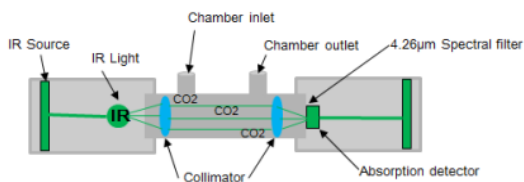

Fig. 2. Focus Radiation NDIR Detector

The single sensor method, providing relative absorption measurement of specific wavelengths, provides measurement at wavelengths of $4.26\mu\text{m}$ for CO_2 gas. This measurement, however, includes error due to the lack of a reference sensor. The dual sensor method is applied in this current study, where the measurement at $4.26\mu\text{m}$ for CO_2 gas is compared to the reference measurement at $3.91\mu\text{m}$, provides less chances of errors by measuring the reference wavelength which is not influenced by other gases.

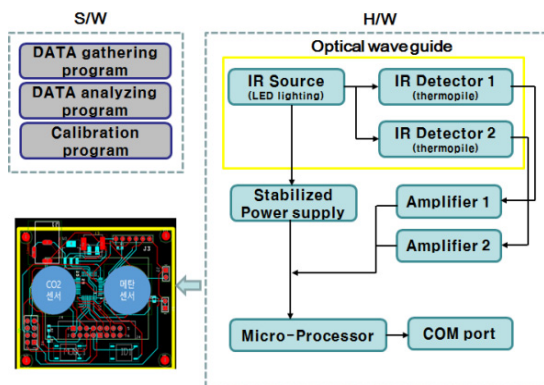

Fig. 3. System Block Diagram

3.2 Gas Cell

The universally used portable and/or small sized gas detectors are designed and produced based on applying four types of optical cavities using single light sources and single chambers. The first concept applies a cylindrical, square-shaped or tube-shaped optical cavity. The second concept applies two light sources with one sensor to compensate the discharge voltage following the heating caused during long-time operation. The third concept adopts the same structural features with the first concept, however provides a Farby-Perot filter to adjust the passing wavelength according to the applied voltage. The fourth concept applies three concave mirrors to maximize the optical path within a limited space within a small gas chamber.

Fig. 4, illustrates the actual design of the aforementioned fourth concept with three concave mirrors to maximize the optical path within small gas chambers. Fig. 5 is the exploded view of the gas chamber of a CO_2 and CH_4 gas detector. This current study selects NDIR SRH-05 CO_2 gas detectors and NDIR SJH-5 CH_4 gas detectors, both manufactured by the Chinese company, Wuhan Cubic Optoelectronics Co., Ltd. for experimental usage. Fig. 6 illustrates the structure and functions of fins within a gas cell, while Table 3, defines the specifications of a CO_2 gas cell.

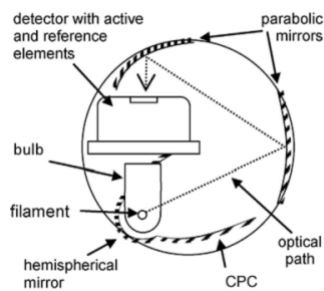

Fig. 4. Design and Shape of Gas Chamber Design



Fig. 5. Exploded View of Gas Cell

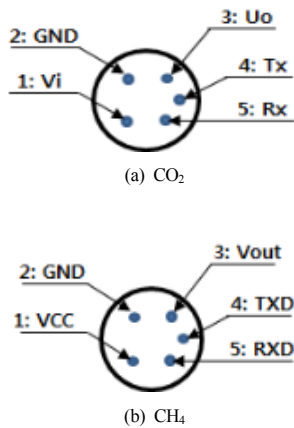

Fig. 6. Pins Structure of Gas Cell

Table 3. CO₂ Sensor Specification

Measurement Range	0~5,000ppm or 0~10%vol
Operating Current	75mA~80mA
Discharge Voltage	DC 0.4V~2V
Operating Voltage	DC 3.5V~6V
Resolving Power	Range A: 0~5000ppm, resolution is 10ppm
Accuracy	Range 0~0.5%

The measurement range of 0~5%vol specified in Table 4, refers to applying the same measurement range of a 100% LEL (Level Explosive Limit). Fields where CH₄ measurement applies are landfill gas, bio gas, and city gas.

Table 4. CH₄ Sensor Specification

Measurement Method	NDIR
Operating Voltage	DC 3.5V~6V
Measurement Range	0~5%vol up to 0~100%vol
Resolving Power	Range 0~5%vol, resolution is 0.01%
Display	4-Digit LED display
Maximum Error	0~1% ±0.1%

3.3 Low Power Driver Circuit

As shown in Fig. 7, once CO₂ or CH₄ is introduced in the optical chamber, infrared is absorbed which

causes change in the electromotive force at the sensor (electromotive force of 350~400mV is generated at CO₂ content 400ppm).

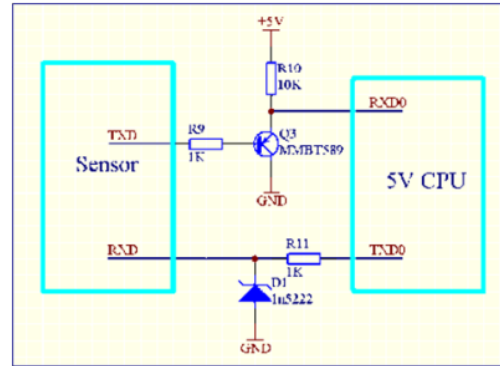

Fig. 7. Sensor Driver Circuit

This electromotive force is amplified and digitalized to provide measurement of gas content.

3.4 Result of Experiment

The IR sensor proposed in this current study is capable of long-distance measurement since having separate senders and receivers. By removing optical choppers and gas cells, all mechanical components are excluded. Locating the IR source and IR detector inside of the sender/receiver collimator provides isolation from the external environment, which eventually provides a minimized influence of any change of the atmospheric condition. The internal sensor module is attached to ad driven by the PCB board.

Reference gas and its supply device is required to conduct a performance test on the developed product. In this current study, practical reasons restricted sourcing such reference gas and supply device, and thus, the measurement testing was conducted up to a laboratory level. The CH₄ measurement test was conducted by monitoring the change in CH₄ content while inserting samples of reference gas to the CH₄ sensor in a controlled method. As shown in Fig. 8, the varying measurement was displayed on the monitor.



Fig. 8. Composite Gas Detector

4. Conclusion

This current study manufactured a composite gas detector providing simulations measurement of CO₂ and CH₄ applying the NDIR method. The measurement range of the device is 0~5,000ppm for CO₂ and 0.5%vol for CH₄, which allows adjudication whether the indoor air quality is complaint to the governmental threshold of maximum 1,000ppm or not. Infrared light is projected through an optical screen, absorbing specific gases, to induce an electromotive force, which is then amplified up to 3.5~6V signals. This process provides an accurate reading by minimizing chances of error. Currently commercialized gas detectors provides measurement and monitoring of single gases or are available at high costs, which limits the chance of universal application. However the product concluded in this current study: shows low power consumption by utilizing ultra-low power circuits; is useful for measuring air quality of factories and facilities by applying a small, portable design fitting in the palm of one hand; and is expected to be effective in fire safety by synchronizing the device with home automation systems to provide automatic fire fighting features.

References

- [1] Zhen Peng, Wu Deng, Rosangela Tenorio, "Investigation of Indoor Air Quality and the Identification of Influential Factors at Primary Schools in the North of China",

www.mdpi.com, *journal sustainability*, 5. July 2017.

- [2] G. Kalyakin, A. Gorbova, E. Brouzgou, "A simple and low-cost amperometric sensor for measuring H₂, CO, and CH₄", *Sensors and actuators. B. Chemical*, vol. 221, 2015.
- [3] A. S. Nasimi, N. Jafari, M. Shabestari, "Ab-initio study of interaction of some atmospheric gases (SO₂, NH₃, H₂O, CO, CH₄ and CO₂) with polypyrrole (3PPy) gas sensor DFT calculations", *Sensors and actuators, B. Chemical*, vol. 220, 2015.
- [4] R. Sun, K. Jeffries, J. B. Socha, J. G. H, "Scanned-wavelength-modulation-spectroscopy sensor for CO, CO₂, CH₄ and H₂O in a high-pressure engineering-scale transport-reactor coal gasfier", vol. 150, 2015.
- [5] M. Choudhary, V. N. Mishra, R. Dwivedi, "Pd-Doped Tin-Oxide-Based Thick-Film Sensor Array for Detection of H₂, CH₄", *Journal of electronic materials*, vol. 42, no. 9, 2013.
DOI: <https://doi.org/10.1007/s11664-013-2663-3>
- [6] E. Nikan, A. Khodadadi, A. Mortazavi, "Highly enhanced response and selectivity of electrospun ZnO-doped SnO₂ sensors to ethanol and CO in presence of CH₄", *Sensors and actuators, B. Chemical*, vol. 184, 2013.
DOI: <https://doi.org/10.1016/j.snb.2013.04.089>

Ik-soo Eo

[Regular member]



- Feb. 1986 : Dept. of electrical engineering, Hanyang University (MS)
- Feb. 2008 : Dept. of computer application engineering, Seoul Venture University(Ph. D.)
- Feb. 1998 ~ current : Honam Univ., Dept. of electrical, Professor

<Research Interests>

Electrical Facilities, Lighting and design, Heat-sink